

FiberView[®] Dairy Waste Sensor System

- ❖ **Reduces plant losses and increases yield and profit**
- ❖ **Isolates operations with high loss**
- ❖ **Allows quick response to loss events**
- ❖ **Operators become more sensitive to losses.**
- ❖ **High Sensitivity: measures 0 to 1% solids**
- ❖ **Uses blue light (470 nm) that responds to both casein and milk fat**
- ❖ **All Stainless Steel construction**
- ❖ **Easy calibration**
- ❖ **Installs in effluent drains**
- ❖ **Difficult locations are available using fiber optic stem length.**

FiberView[®] Dairy Waste Sensor System reduces the Biochemical Oxygen Demand (BOD) and sewage costs from improved operations practice. Less milk loss means reduced product shrink resulting in lower costs, higher yields, and higher profits. The FiberView DWS System enables the location, occurrence or concentration of the discharge to be determined. It monitors solids concentration in dairy plant effluents in the range of 0 to 1% solids (or higher). It has a quick response to loss events and provides time to take corrective actions. Operators become sensitive to losses.

The FiberView sensor measures light backscatter using optical fibers as shown in the following sketch:

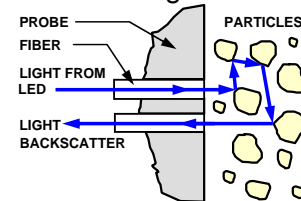

The FiberView DWS System is normally configured with an Anderson AJ-300 circular chart recorder. This provides a visual record of effluent solids concentration vs. time and alarm features.

See the Reflectronics web site for more details.



FiberView Technical Specifications

- ❖ Standard Compliance: NEMA 4X (water tight, corrosion resistant); CE Mark Verified Class A under EN 61326-1 CE Mark Safety EN 61010-1
- ❖ Sensor O-Ring: EPDM (ethylene propylene rubber)
- ❖ Sensor housing: 316 SS
- ❖ Optical Fibers: Silica
- ❖ Fiber attachment: Gold soldered
- ❖ LED wavelength: 470 nm standard (880 nm optional)
- ❖ Output signal: 4-20 mA with analog zero and span calibration
- ❖ Cable: Quick disconnect, water tight
- ❖ Operating Temperature Limits: Head, 60 °C; Probe, 100 °C
- ❖ Connections: 1.5, 2, 2.5, and 3" Tri-Clamp
- ❖ Power Supply: 10 to 27 VDC, 100 mA max., low noise.
- ❖ Signal/Noise Ratio: > 1300 @ 4mA
- ❖ High Detection Sensitivity: Full scale for 0 to 10% milk (1% solids) in water
- ❖ Serial and Model Number: Etched onto SS (# plus mfg. date; 123-123104)

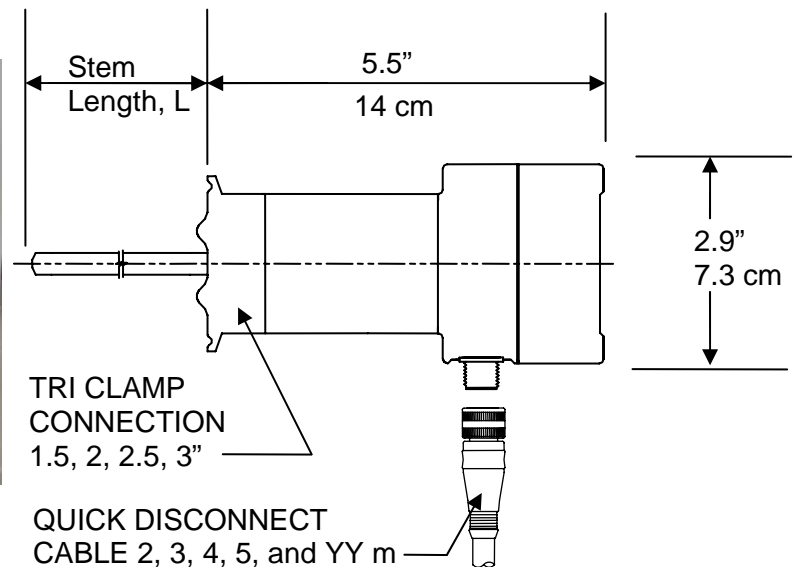

Specifying a FiberView Dairy Waste Sensor for ordering: DWS-X-YY- L

Where

- X = Tri Clamp size: A (1.5"), B (2.0"), C (2.5") or D (3.0")"**
- YY = Quick disconnect cable length: 02, 03, 04 and 05 m are standard. Longer lengths, YY, are special order.**
- L = Stem length in cm (inches x 2.54)**