

CoAguLite™ Cutting Time Control Technology

- ❖ Improves moisture control
- ❖ Reduces whey fat losses
- ❖ Reduces fines losses
- ❖ Replicates the cheesemaker's cutting time selection
- ❖ Provides consistent selection of cutting time
- ❖ Alerts of non standard vats
- ❖ Measures coagulation reaction kinetics
- ❖ Easy calibration
- ❖ 3-A Compliant

The CoAguLite Cutting Time Control Technology provides consistent cutting time control, reduces whey fat and fines losses and improves moisture control. Determination of the enzymatic reaction rate of the coagulating milk gives this technology the ability to adjust for changes in temperature, pH, added calcium, enzyme concentration or milk reactivity. Precise measurement of small changes in aggregation of casein is enhanced by the use of miniature optical fibers in a unique sensor configuration. A CoAguLite sensor and PLC software (data processing algorithm and a prediction model) are used to implement this technology.

T_{max} is a direct measurement of enzyme kinetics and is obtained from the sensor data and used to predict cutting time as follows:

$$T_{cut} = BETA * T_{max}$$

BETA is a constant selected by the cheesemaker that calibrates the system. A cutting time prediction model that corrects for protein variation is available.

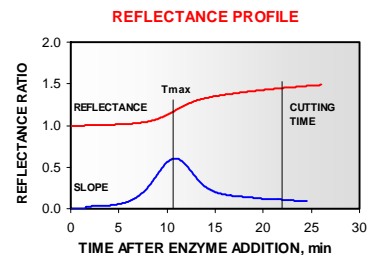

See the Reflectronics web site for more details.



CoAguLite Technical Specifications

- ❖ Standard Compliance: NEMA 4X (water tight, corrosion resistant);
CE Mark Verified Class A under EN 61326-1
CE Mark Safety EN 61010-1
3A Sanitary Standard 46-03
- ❖ Sensor and ferrule O-Ring: EPDM (ethylene propylene rubber)
- ❖ Sensor housing and ferrule: 316 SS
- ❖ Plastic probe: Ertalyte
- ❖ Optical Fibers: Silica
- ❖ Fiber attachment: Gold soldered
- ❖ Output signal: 4-20 mA with analog zero and span calibration
- ❖ Cable: Quick disconnect, water tight , 5 m (16 ') standard
- ❖ Operating Temperature Limits: Head, 60 °C; Probe, 100 °C
- ❖ Connections: 2.5" Tri-Clamp
- ❖ Power Supply: 10 to 27 VDC, 100 mA max., low noise.
- ❖ Signal/Noise Ratio: > 1300 @ 4mA
- ❖ High Detection Sensitivity: Full scale for 0 to10% milk in water
- ❖ Serial and Model Number: Etched onto SS (# plus mfg. date; 123-123104)

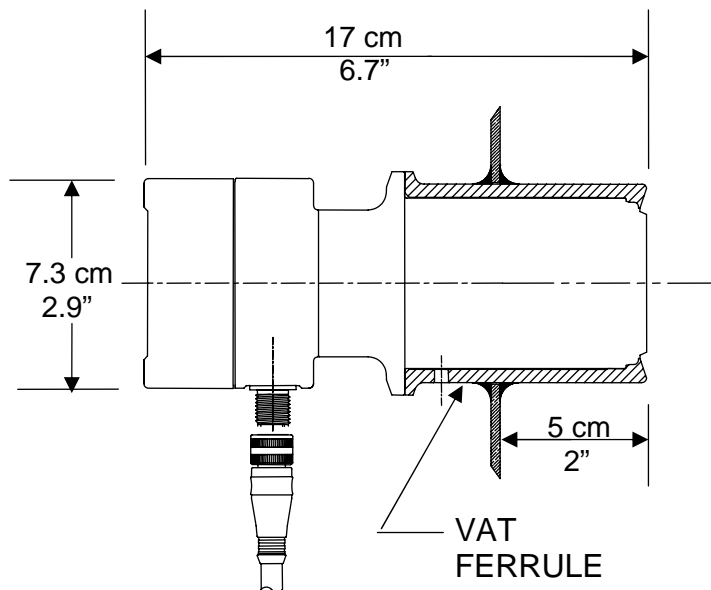

ITEM	DESCRIPTION	PART NO.
	CoAguLite Model 5	
1	Sensor Assembly (Items 2, 4, 5, 6, 7)	501
2	CoAguLite Sensor	502
3	Cordset	503
4	Plug	504
5	Tri Clamp 2.5"	505
6	O-Ring	506
7	Ferrule	507

The CoAguLite Cutting Time Control Technology is currently being implemented in the hard cheese and cottage cheese processes by:

CPS Scherping
P.O. Box 10
801 Kingsley Street
Winsted, MN 55395

TEL: +1 320 485 4401
+1 800-669-4401
FAX: +1 320 485 2666
mail@scherpingsystems.com